

SN236 Series
DO160 Qualified

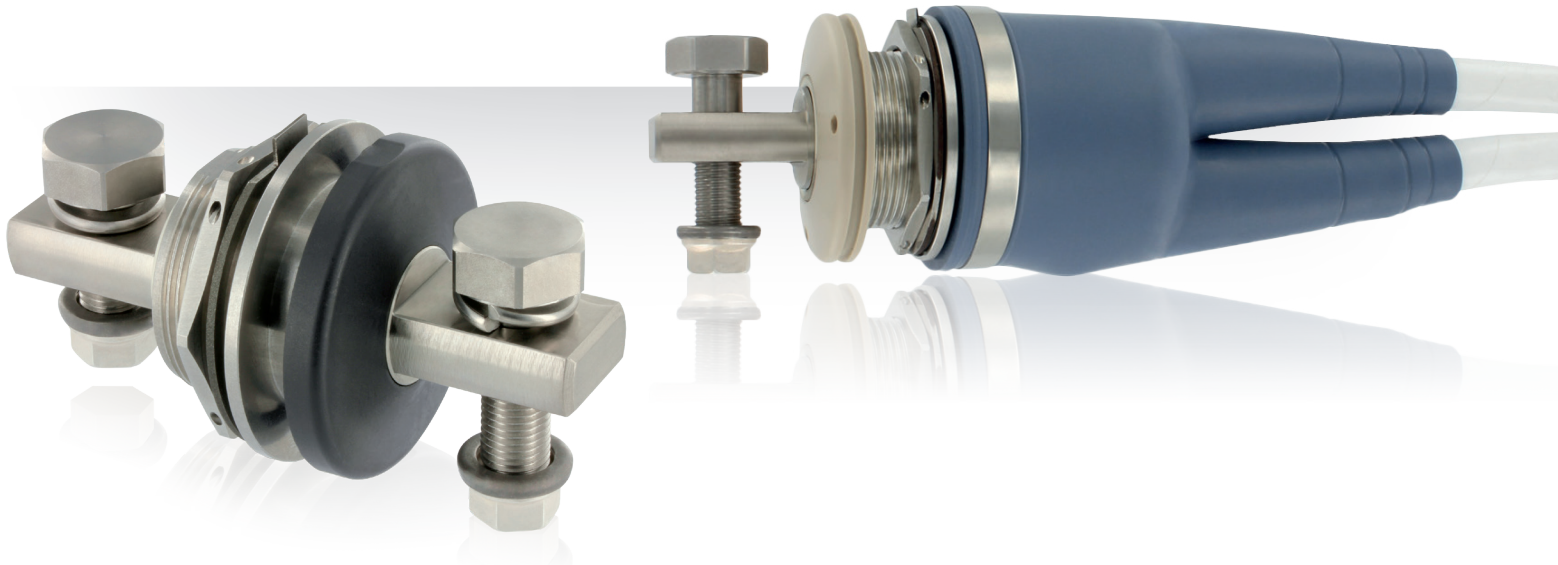

Fireseal High Power Feedthrough

DO160 index G qualified solution ideal for Engines and APU.

- Fire protective power feedthrough** ■ Prevent from fire propagation thanks to its ceramic insulator resisting to 1100°C during 15min.
- High temperatures resistant** ■ Can operate up to 200°C continuous.
- High power lug terminations** ■ For aluminum or copper cables, up to 350A at 600 Vrms.
Specific « umbrella » design to prevent condensation to cause arching.
- Pressure resistant** ■ Maintain pressure boundaries.
Leak rate $<10^{-6}$ atm.cm³/s at 1 bar pressure difference.

Description

- Ideal for engine and APU applications
 - Fire protective power feedthrough
 - High temperatures resistant
 - High power lug terminations
 - Pressure resistant
- SN236HTFWC meets performances of the DO160 index G requirements.
- Exceptional water tightness
Feedthrough with protective boot completely immersed in water.
- Tailor-made design can be done to adapt your specific current, contacts orientation or temperature.



Technical features

Mechanical

- **Shell:**
Stainless steel
- **Insulator and sleeve:**
Alumina and Peek 50% glass fiber
- **Central bar contact:**
Nickel
- **Tightening torque of screws:**
1.4 M.DaN
- **Terminal lugs:**
AWG #0 , #00, #000

Climatic

- **Operating Temperature:**
-55°C / +200°C
- **Fire resistance:**
1100°C during 15 minutes without flame penetration
- **Salt spray:**
48 h
- **Sealing:**
Leak rate <math> < 10^{-6}</math> atm.cm³/s with
Delta P=1bar (helium test)
- **Conformity:**
SN236HTFWC meets performances of the
DO160 Index G requirements

Electrical

- **Insulation resistance**
Normal conditions: IR > 500M Ω - 500V DC
High Operational T^o: IR > 200M Ω - 500V DC
Humidity: IR > 50M Ω - 500V DC
Fireproof: IR > 100k Ω - 500V DC
- **Dielectric Withstanding Voltage**
DWV under 4.2 kVDC, leakage current <math> < 1\mu</math>A
- **Working voltage and current**
Normal use: U = 115V RMS
U_{Max} = 600V RMS
I_n = 350A
I_{peak} = 1043A during 5 sec. at beginning
- **Frequency**
From 360 to 800 Hz

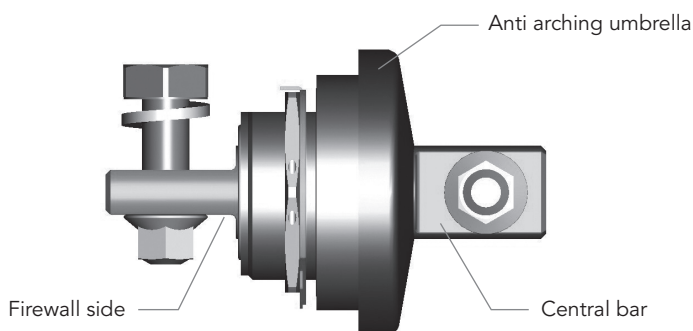

Ordering information

Part Number	Description
SN236HTFWC	Connector
SN236PB10	Protective boot for 1 cable
SN236PB20	Protective boot for 2 cables
SN236PBA	Protective boots adaptor
SN236PBAT	Protective boots adaptor tool

SN236PB10
Protective boot for 1 cable

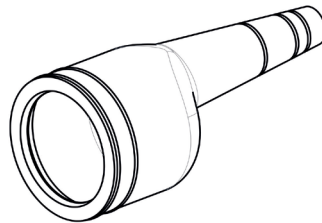

SN236PB20
Protective boot for 2 cables

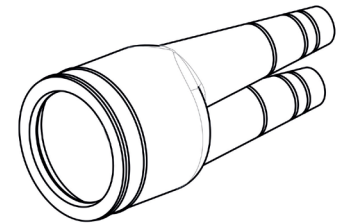

DO160 Index G requirements

Characteristics	Level
Waterproofness	DO160 - Section 10, equipment category R: Spray Proof
Thermal shock and cycle	DO160 - Section 5, equipment category A: Temperature variation from -55°C (low operational temperature) to +148°C (high operational temperature) with slope of 10°C/min maxi
Operational shock and crash safety	DO160 - Section 7, equipment category B and E: <ul style="list-style-type: none"> · 18 shocks saw-tooth wave shape (6 orientations x3 shocks) to 6g/11ms (category B) and to 6g/20ms (category E). · Impulse test: 6 shocks saw-tooth wave shape (6 orientations x1 shock) to 20g/11ms (category B) and to 20g/20ms (category E). · Sustained test: 6 constant acceleration test (6 orientations) of 3s each to 20g max per orientation.
Vibrations	DO160 - Section 8, equipment category S(D), R(D&D1) and H(P): <ul style="list-style-type: none"> · Category S: 1 hour/axis, sine or random at performance level. 10-2000 Hz, 8.92g · Category R: Sine of 3 hours/axis less 30min/dwell (max 4 dwells) or random at performance level (minimum of 10 minutes) and 3 hours endurance level (repeat in all 3 axes). 10-2000 Hz, 12.61g · Category H: High g / low f, sine sweep each axis. 10-250 Hz, ±10g
Temperature and altitude	DO160 - Section 4, equipment category D2: <ul style="list-style-type: none"> · Ground survival low temperature test and short-time operating low temperature test: -60°C / 3h (not operating) then -60°C / 1h (operating) · Operating low temperature test : -55°C / 2h (operating) · Ground survival high temperature test and short-time operating high temperature test: +200°C / 3h (not operating) then +148°C / 1h (operating) · Operating high temperature test: +148°C / 2h (operating) · Altitude test: 50kft / 15.2km / 116mbar / 2h (operating)
Icing	DO160 - Section 24, equipment category A: 3 cycles from -55°C / HR ambient to +30°C / ambient pressure / 95% HR and return, to create frost on the piece, then checking good equipment operation at -10°C.
Humidity	DO160 - Section 6, equipment category B: 10 cycles of 24h, equipment non operational
Fireproof	DO160 - Section 26, equipment category A
Flammability	DO160 - Section 26, equipment category C
Salt fog	DO160 - Section 14, equipment category T
Fluids susceptibility	DO160 - Section 11, equipment category F: The liquids used for the tests are: fuels, hydraulic fluids, lubricating oils, solvents and cleaning fluids, de-icing fluids, insecticides
Sand and dust	DO160 - Section 12, equipment category D and S
Fungus resistance	DO160 - Section 13, equipment category F: Fungus application during 28 days
Explosive atmosphere	DO160 - Section 9, equipment category H: No feedthrough surfaces have to reach a temperature of 204°C during powering with 350A current.

Dimensions

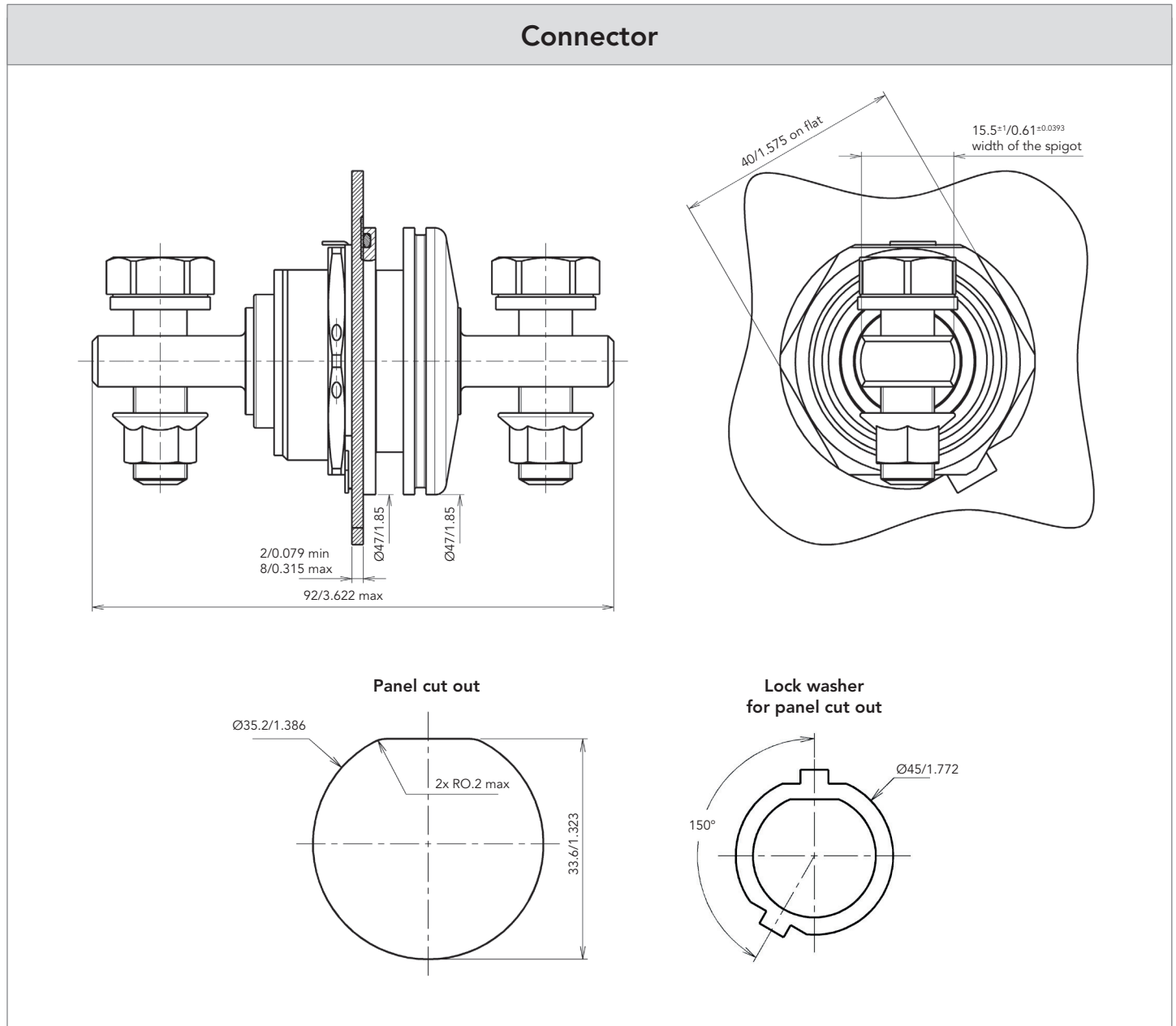

Note: All dimensions are in millimeters and inches (mm/inch).
 Dimensions are for information only. Please consult us for customer drawings.

Protective boot for 1 cable

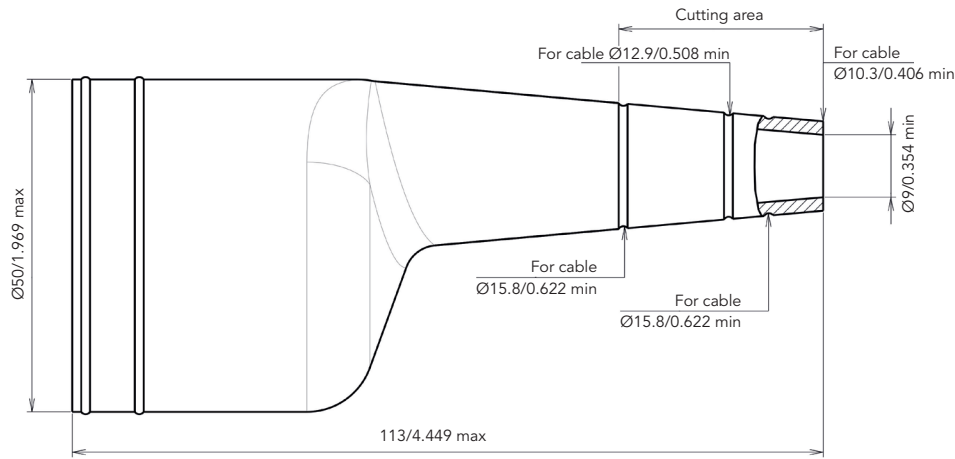

Part Number:
SN236PB10

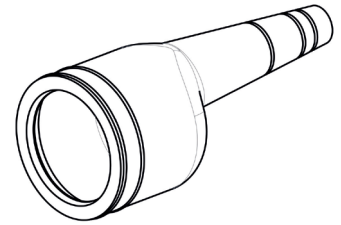

Protective boot for 2 cables

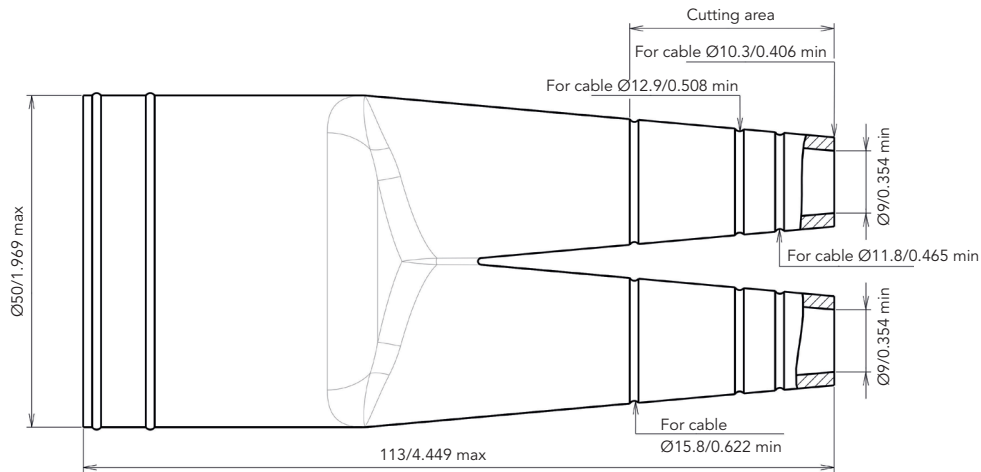

Part Number:
SN236PB20

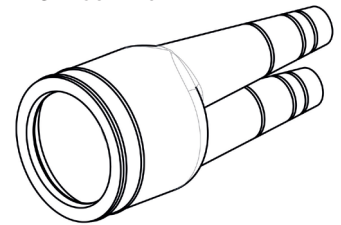

Note: All dimensions are in millimeters and inches (mm/inch).

For further information contact us at technical.emear@souriau.com (Europe - Asia - Africa)
technical.americas@souriau.com (North America)
 or visit our web site www.souriau.com